

R725-RO

HIGH RESOLUTION STEPPER DRIVE

USER MANUAL

VERSION 1.00



TABLE OF CONTENTS

USER MANUAL.....	1
KEY NEW FEATURES OF THE R725:	3
PHYSICAL DIMENSIONS AND PINOUT	4
MECHANICAL DRAWING.....	5
ELECTRICAL RATINGS.....	5
CONNECTION DIAGRAM.....	7
EXTERNAL CURRENT SET RESISTOR.....	9
ONBOARD STANDBY TRIMPOT	10
EXTERNAL STANDBY RESISTOR	11
UNDERSTANDING INPUTS: STEP, DIRECTION, COMMON, RESET, AND ENABLE.....	12
UNDERSTANDING OUTPUTS: FULLSTEP AND FAULT	13
EXPLANATION OF FEATURES.....	13
APPENDIX.....	14
DISCLAIMER	15

Thank you for purchasing Lin Engineering's R725 motor control. The R725 is a from-the-ground-up stepper motor controller design and uses multiple proprietary techniques to run a stepper motor smoother, quieter and with more power than other drives in its price range. This document seeks to quickly get your R725 up and running and will explain each new feature and its utility for your application. Let's begin:

KEY NEW FEATURES OF THE R725:

1. Form, fit, and function compatibility with IM483 and IM805 applications.

The R725 was designed as a drop-in replacement for the discontinued IM483 and IM805 stepper motor controls. Dimensions and pinout are identical, but with the numerous technological advantages of a modern stepper drive.

2. Cooler running temperature

Upgraded and over-rated power section components reduce heating by up to 30% compared to previous revisions.

3. Next-generation resonance compensation.

Midband instability and resonance is compensated for using all new algorithms, eliminating resonant frequencies at the midband completely, with no adjustment necessary. The R725 will run a motor smoothly out of the box.

4. Extra resolution choices.

Ranging from half-step to 256-microstep resolution, a stepper motor can be run with resolution of up to 51,200 pulses per revolution.

2	5
4	10
8	18
16	50
32	100
64	180
128	
256	

5. Push Button Self-Test.

Testing and tuning stepper motors can now be done simply with an onboard self-test button. Simply pushing and holding this button down will run the motor CW and CCW at low speed, allowing easy tuning for motor resonance with the onboard adjustment trimpot.

6. Resolution upscaling at low speeds.

Every microstep is further broken down into higher interpolated microsteps to increase motor smoothness at extremely low speeds. The resolution upscaling will change depending on the microstep resolution chosen via DIP switch to be sure your motor is getting the smoothest possible operation at all times.

7. User adjustable standby current.

If the onboard DIP switch is used to set phase current the user can adjust a trimpot for holding torque from 0% - 100% current in standby mode. If an external resistor or voltage is used the user may use a second resistor to set standby current, allowing full customization on multi-axis applications.

PHYSICAL DIMENSIONS AND PINOUT

There are two connectors on the R725: A high power connector for motor and power supply connections called CN1 (P2 on the PCB) and a low power signal connector for I/O called CN2 (P1 on the PCB). The pinouts from left to right while facing the connector are below. All 8 pins on CN2 are optically isolated and there is no galvanic connection from any pin to the drive.

PIN NUMBER	CN1	CN2
PIN1	Standby	Optoisolator Ground
PIN2	Current Set	Step
PIN3	Ground	Direction
PIN4	Supply DC+	Optoisolator +5V
PIN5	Phase /B	Enable
PIN6	Phase B	Reset
PIN7	Phase /A	Fault
PIN8	Phase A	Full Step Out

MECHANICAL DRAWING

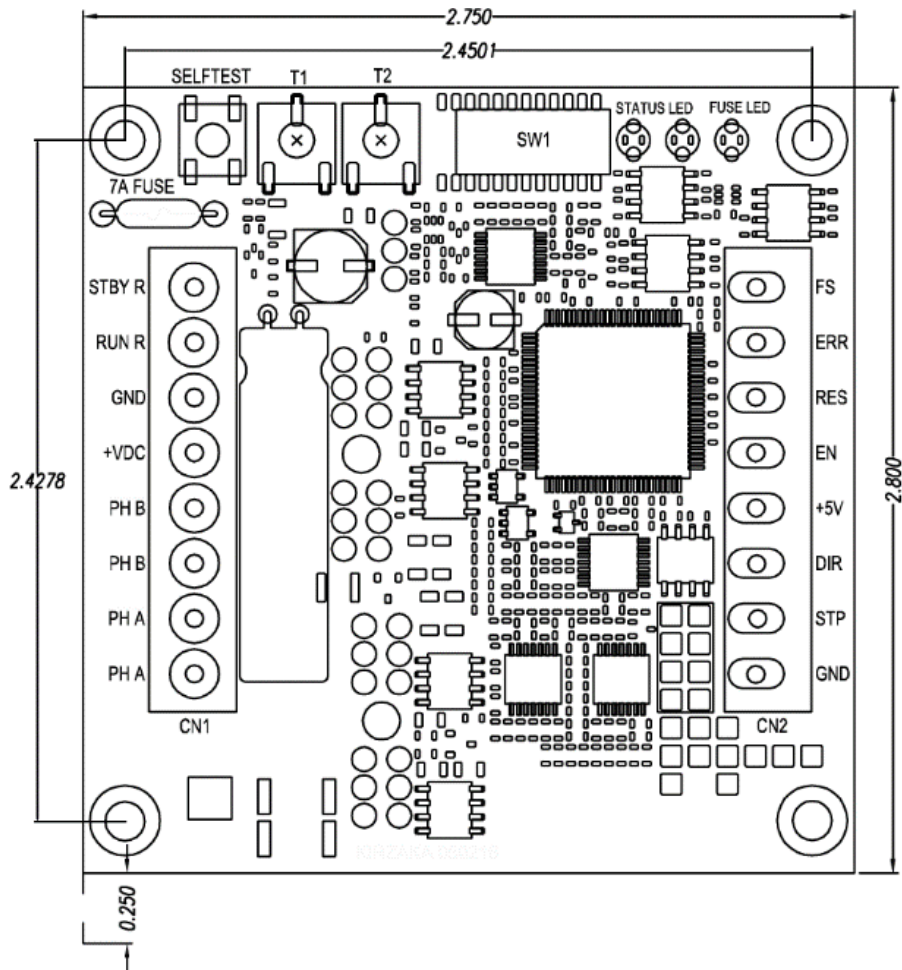

ELECTRICAL RATINGS

SPECIFICATION	DEVICE	TEST CONDITION	FUNCTION	MIN	TYP	MAX	UNIT
Input voltage				18		80	V
Output current						7	A
Input forward current continuous	HCPL2531		STP, DIR			25	mA
Input forward current peak	HCPL2531		STP, DIR			50	mA
Input forward voltage	HCPL2531	IF=16mA	STP, DIR		1.45	1.7	V
Input reverse breakdown voltage	HCPL2531	IR=10uA	STP, DIR	5.0			V
Output current	HCPL2531		STP, DIR			8	mA
Input forward current continuous	MOCD		EN, RES			60	mA

Input forward current peak	MOCD	PW=100us, 120pps	EN, RES			1.0	A
Input forward voltage	MOCD	IF=30mA	EN, RES		1.25	1.55	V
Input reverse breakdown voltage	MOCD		EN, RES	6.0			V
Collector current continuous	MOCD		EN, RES			150	mA
Collector-emitter breakdown voltage	MOCD	IC=100uA	EN, RES	70	100		V
DC output current	NC7WZ		STPO, FAULT			100	mA

PIN#	FUNCTION	DETAILS
1	GND	Signal Ground
2	STP	The edge of step pulse on this input advances the motor one increment. The size of the increment is dependent upon the settings of the resolution.
3	DIR	This input is used to change the direction of the motor.
4	+5V	This +5VDC input is used to supply power to the isolated logic inputs.
5	ENABLE	This input is used to enable/disable the output section of the driver. When in a Logic HIGH state (open), the outputs are enabled.
6	RESET	When LOW, this input will reset the driver (phase outputs will disable).
7	FAULT OUTPUT	This output indicates that a short circuit condition has occurred. This output is active LOW.
8	FULLSTEP OUTPUT	This output indicates when the driver is positioned at full step. This output can be used to count the number of full steps the motor has moved, regardless of the number of microsteps in between.

PIN#	FUNCTION	DETAILS
1	REDUCE CURRENT	Phase Current Reduction Adjustment
2	CURRENT	Phase Current Adjustment
3	GND	Power Ground. The ground, or return, of the power supply is connected here
4	V+	Motor Supply Voltage. +18V to +80VDC
5	~PHB	~PHASE B of the stepping motor
6	PHB	PHASE B of the stepping motor
7	~PHA	~PHASE A of the stepping motor
8	PHA	PHASE A of the stepping motor

CONNECTION DIAGRAM

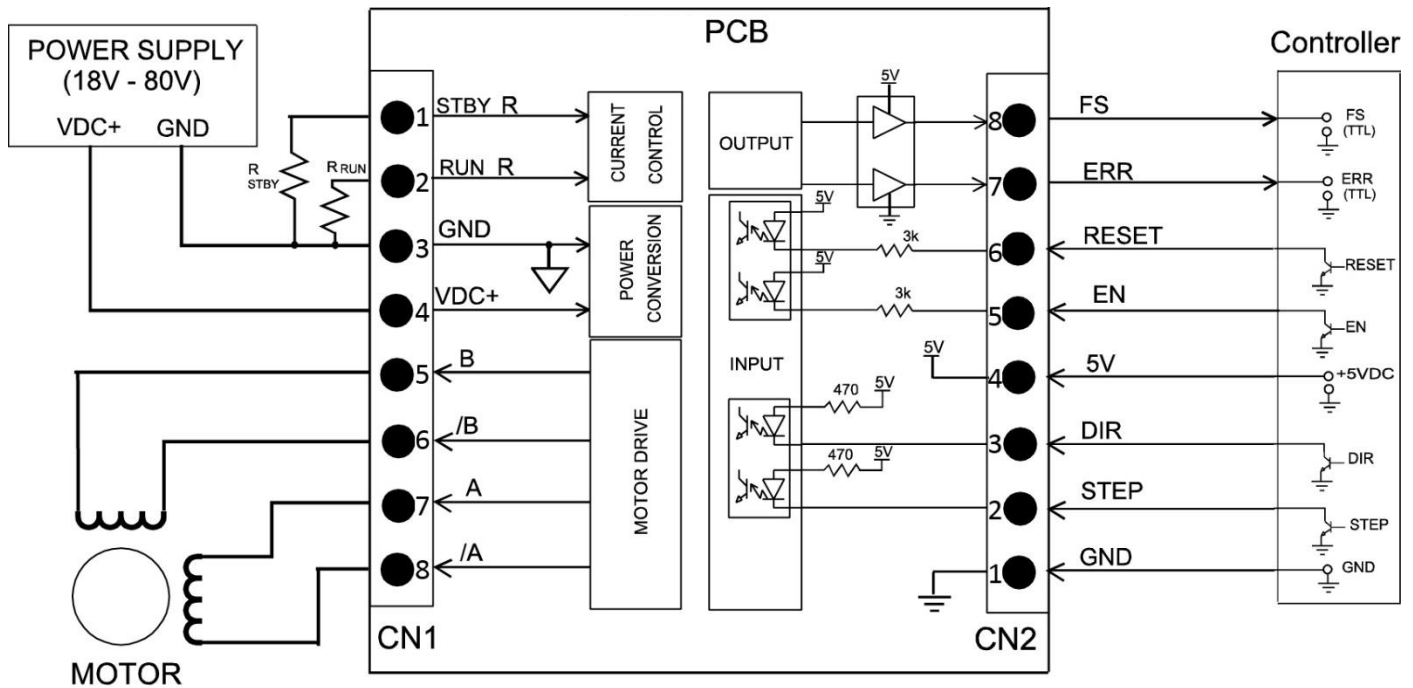

- NOTE:
- 1) $R_{RUN} = I_{PEAK} \times 500$ (Use 1/8W 1% Resistors)
 - 2) $R_{STBY} = 500 \times \frac{I_{RUN} \times I_{HOLD}}{I_{RUN} - I_{HOLD}}$ (Use 1/8W 1% Resistors)
 - 3) There are 2 different grounds in the system: Power supply ground (∇) and 5V ground (\perp)
 - 4) RESET, EN, DIR, STEP are active low inputs (should be connected to \perp using mechanical switches or open collector transistors)
 - 5) FS and ERR are TTL Outputs (5V) with a Source/Sink Current of +/-24mA with respect to \perp

STEP 1: APPLYING POWER AND CONNECTING A MOTOR

POWER SUPPLY HOOKUP

- CN1 PIN 3** Power Ground
Connect the power supply ground to this terminal
- CN1 PIN 4** Power (+)
Connect the power supply "+" to this terminal

The power supply voltage must be between 18 VDC and 80 VDC. The maximum power supply current required is 67% of the motor's rated phase current. An unregulated power supply may be used as long as the voltage stays between the limits; keep the ripple voltage to 10% or less for best results. The drive has a 2 second power-on reset time before the motor is energized.

CAUTION: Power supply voltage in excess of 80VDC will damage the R725

The choice of power supply voltage depends on the high speed performance required of the motor; doubling the voltage doubles the motor's high speed power. In all cases the power supply voltage should be no less than 4 times or no more than 25 times the motor's rated voltage. The motor may not run as smoothly as possible if the power supply voltage is less than 4 times the motor's rated voltage. A power supply voltage greater than 25 times the motor's rated voltage will overheat and damage the motor, even if it is not turning. Motor winding inductance should be 500uH or greater, but generally no more than 7mH for best performance. A practical limit for stepper motors is 50mH.

A more accurate calculation of maximum power supply voltage is to find your motor's inductance, and put it into the following equation.

$$32 * (\sqrt{\text{mH inductance}}) = \text{Power Supply Voltage}$$

If your motor has 2mH of inductance, the equation would look as follows.

$$32 * (\sqrt{2}) = 45.12V$$

That motor's maximum power supply would be 45VDC. All power supply voltages below that limit will work without unnecessarily heating the motor. A calculated voltage above 80VDC should be run at 80VDC or below, and will not impact motor performance substantially if the motor inductance is below 50mH.

MOTOR CONNECTION

CN1 PIN 8 Phase A
Connect the other end of the winding to this terminal

CN1 PIN 7 Phase /A
Connect the other motor winding to this terminal

CN1 PIN 6 Phase B
Connect the other end of the winding to this terminal

CN1 PIN 5 Phase /B
Connect one motor winding to this terminal

Connect one motor winding to terminals 5 and 6. Connect the other winding to terminals 7 and 8. Turn the power supply off when connecting or disconnecting the motor. If the motor turns in the wrong direction, reverse the motor winding connections to terminals 5 and 6.

4-wire, 6-wire and 8-wire motor may be used. When 6-wire motors are used, they may be connected in half winding or full winding. This is equivalent to an 8-wire motor connected in parallel or series. If a motor is connected in series or full winding, the motor's phase current rating is half of its parallel or unipolar rating. The choice depends on the high-speed performance required; a parallel-connected motor will provide twice the power of a series-connected motor at the same power supply voltage.

STEP 2: SETTING MOTOR PHASE CURRENT

Motor phase current may be set one of three ways: The onboard DIP switches, an external current set resistor or an external voltage input. All current settings will be in reference to the single phase peak current of the stepper motor.

ONBOARD DIP SWITCH SETTING

Please consult the diagram below for the proper switch setting for your motor phase current. Leave CN1 PIN2 floating if this option is being used. RED = OFF, GREEN = ON in the current set diagram.

MOTOR CURRENT SETTINGS (SW5 - SW10)

5 6 7 8 9 10					5 6 7 8 9 10					5 6 7 8 9 10					5 6 7 8 9 10								
0.00A	■	■	■	■	■	2.06A	■	■	■	■	■	4.23A	■	■	■	■	■	6.28A	■	■	■	■	■
0.13A	■	■	■	■	■	2.20A	■	■	■	■	■	4.35A	■	■	■	■	■	6.41A	■	■	■	■	■
0.26A	■	■	■	■	■	2.33A	■	■	■	■	■	4.48A	■	■	■	■	■	6.54A	■	■	■	■	■
0.38A	■	■	■	■	■	2.47A	■	■	■	■	■	4.61A	■	■	■	■	■	6.67A	■	■	■	■	■
0.51A	■	■	■	■	■	2.61A	■	■	■	■	■	4.74A	■	■	■	■	■	6.80A	■	■	■	■	■
0.64A	■	■	■	■	■	2.73A	■	■	■	■	■	4.87A	■	■	■	■	■	6.93A	■	■	■	■	■
0.77A	■	■	■	■	■	2.86A	■	■	■	■	■	5.00A	■	■	■	■	■	7.05A	■	■	■	■	■
0.90A	■	■	■	■	■	3.00A	■	■	■	■	■	5.13A	■	■	■	■	■	7.18A	■	■	■	■	■
1.03A	■	■	■	■	■	3.14A	■	■	■	■	■	5.26A	■	■	■	■	■	7.30A	■	■	■	■	■
1.15A	■	■	■	■	■	3.27A	■	■	■	■	■	5.38A	■	■	■	■	■	7.43A	■	■	■	■	■
1.28A	■	■	■	■	■	3.41A	■	■	■	■	■	5.51A	■	■	■	■	■	7.56A	■	■	■	■	■
1.41A	■	■	■	■	■	3.55A	■	■	■	■	■	5.64A	■	■	■	■	■	7.69A	■	■	■	■	■
1.54A	■	■	■	■	■	3.70A	■	■	■	■	■	5.77A	■	■	■	■	■	7.81A	■	■	■	■	■
1.66A	■	■	■	■	■	3.83A	■	■	■	■	■	5.90A	■	■	■	■	■	7.94A	■	■	■	■	■
1.79A	■	■	■	■	■	3.96A	■	■	■	■	■	6.03A	■	■	■	■	■	8.07A	■	■	■	■	■
1.92A	■	■	■	■	■	4.10A	■	■	■	■	■	6.15A	■	■	■	■	■	8.20A	■	■	■	■	■

EXTERNAL CURRENT SET RESISTOR

An external current set resistor can be used, which will be connected between CN1 PIN 2 (Current Set) and CN1 PIN 3 (GND). The formula for the current set resistor is below:

$$R_i = I_{PEAK} \times 500$$

For a 3.2A motor the equation would look like below:

$$R_i = 3.2 \times 500$$

$$R_i = 1600$$

This would mean a 1.6K resistor would be the calculated resistance value. If the calculated resistance is a nonstandard value, it is safe to use the closest 5% resistor that is less than the calculated value. For instance, a 4.6A motor would need a 2.3K resistor; the nearest 5% value is a 2.2K resistor which would result in roughly 96% of the motor's rated current (4.4A). The resistor leads should be kept as short as possible to prevent noise problems.

STEP 3: SELECTING MICROSTEP RESOLUTION

Choosing microstep resolution will determine how many revolutions your motor moves with a given frequency. To calculate how many pulses per revolution your motor will move you simply calculate the number of full steps per revolution by the microstep setting. For example, a standard 1.8 degree (200 full steps per revolution) stepper motor with a R725 set to 25 microstep will require 5,000 pulses per revolution.

The resolution should be set on the DIP switch according to the diagram below.

MICROSTEP RESOLUTION (SW1 - SW4)

	1	2	3	4
2 uSTEP	Green	Green	Green	Green
4 uSTEP	Red	Green	Green	Green
8 uSTEP	Green	Red	Green	Green
16 uSTEP	Red	Red	Green	Green
32 uSTEP	Green	Green	Red	Green
64 uSTEP	Red	Green	Red	Green
128 uSTEP	Green	Red	Red	Green
256 uSTEP	Red	Red	Red	Green

	1	2	3	4
5 uSTEP	Green	Green	Green	Red
10 uSTEP	Red	Green	Green	Red
20 uSTEP	Green	Red	Green	Red
50 uSTEP	Red	Red	Green	Red
100 uSTEP	Green	Green	Red	Red
200 uSTEP	Red	Green	Red	Red
18 uSTEP	Green	Red	Red	Red
180 uSTEP	Red	Red	Red	Red

STEP 4: SETTING STANDBY CURRENT

After the R725 has not received step pulses for one second it will enter standby mode, where it will limit current to a user-set percentage of maximum current. The R725 will enter reduced-heating switching mode during this time to further decrease motor temperature during times of inactivity. There are two ways to set the standby current value.

ONBOARD STANDBY TRIMPOT

Trimpot T2 on the R725 is dedicated to setting the standby current value. Turning this fully CCW (8 o'clock) will reduce current to 0% of the set value, while turning it fully CW (4 o'clock) will set the standby current to 100% of set

current. This trimpot is a single turn component with a total range of approximately 270° of motion. A diagram of the adjustment trimpot is below:

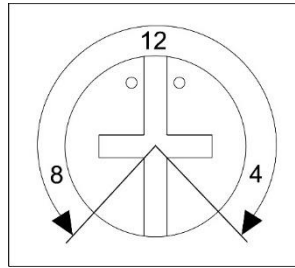

EXTERNAL STANDBY RESISTOR

An external resistor can be used to set the standby current on the R725 in lieu of using the onboard trimpot. If any method of current set but the DIP switch is used then this is the mandatory way of setting standby current. This resistor will be placed between CN1 PIN 1 (Standby Set) and CN1 PIN 3 (GND)

The formula for the resistor is below:

$$R2 = 500 * (\text{Run Amps} * \text{Standby Amps}) / (\text{Run Amps} - \text{Standby Amps})$$

If a motor is rated for 6A and a standby current of 2A is required, the formula would be worked out as below:

$$R2 = 500 * (6A * 2A) / (6A - 2A)$$

$$R2 = 500 * 12 / 4$$

$$R2 = 1500$$

In this example you would want to use a 1.5K resistor between CN1 PIN 1 (Standby Set) and CN1 PIN 3 (GND). Component tolerance for this setting can be 5%, so the nearest 5% resistor value to the calculated value is acceptable. As with the current set resistor, the component leads should be kept as short as possible to prevent noise problems.

STEP 5: USING PUSH-BUTTON SELF-TEST TO VERIFY MOTOR CONNECTIONS

Once the motor is connected to the R725 power may be applied to the drive. The motor should have holding torque (resist being rotated by hand) and the green indicator LED should be blinking. You may now begin self-test and tuning.

In order to use the onboard self-test you will need to locate the button near TRIM1. The button should be pushed with either a finger (without the cover) or with a blunt nonconductive rod (like a ceramic screwdriver or plastic dowel). As long as the button is depressed the motor will move one revolution CW and one revolution CCW when set to ten microstep. The amount of rotation will change based off of resolution settings, because the self-test outputs a set number of step pulses.

With the motor verified to run correctly, you may move on to the fourth and final step to getting the drive to run.

STEP 6: CONNECTING STEP AND DIRECTION SIGNALS

CN2 PIN 1	Signal GND This pin is optional. This pin must connect to the controller ground terminal if the drive's FAULT and FULL-STEP outputs are going to be used; otherwise it can be left unconnected.
CN2 PIN 2	Step This input pin connects to the controller's STEP output. The input accepts 3.3V and 5V logic level signals; if 3.3V logic is used, a 3.3VDC supply voltage from the controller must be connected to Pin 4. The maximum step pulse frequency is 2.5 MHz, the minimum logic '0' time is 200ns and the minimum logic '1' time is 200ns. The STEP input current is -2.5 mA with 3.3V logic and -5 mA when 5V logic is used. Stepping occurs on the positive going edge of the STEP input.
CN2 PIN 3	Direction This input pin connects to the controller's DIRECTION output. The input accepts 3.3V and 5V logic level signals; if 3.3V logic is used, a 3.3VDC supply voltage from the controller must be connected to Pin 4. The minimum setup time is 0ns and the minimum hold time is 500ns. The DIRECTION input current is -2.5mA with 3.3V logic and -5mA when 5V logic is used.
CN2 PIN 4	Common This pin connects to the controller's +5VDC supply terminal if 5V logic is used or a +3.3VDC supply terminal if 3.3V logic signals are used. The maximum current draw from the supply is 15mA at +5VDC or 8mA at +3.3VDC. The absolute maximum voltage limits to this pin is -0.3VDC and +6VDC.

UNDERSTANDING INPUTS: STEP, DIRECTION, COMMON, RESET, AND ENABLE

All control inputs on the R725 are opto isolated for protection. The user may connect +3.3VDC or +5VDC to control supply inputs and the maximum current draw will be 15mA on all inputs. An explanation for each input is below:

RESET: This pin is optional. This pin connects to the controller's RESET output; otherwise it can be left unconnected. A logic '1' on this pin allows the drive to run the motor if the ENABLE input is a logic '1' or unconnected. A logic '0' resets the drive's internal microstep counter to zero, phase A 'off' and phase B 'on'. The RESET input should be used if it's necessary to have an emergency stop input. Cycling the RESET input (hold at logic '0' for one second, then at logic '1') also clears latched fault conditions such as short-circuit and over-temperature protection provided the triggering cause has been cleared. If no latched faults exist, the minimum RESET logic '0' time is 20us.

ENABLE: Freewheels motor and stops all motor switching when a logic '0' is applied. The motor will have no holding torque and can be manually manipulated. Upon a logic '1' being applied the R725 will move the motor to the nearest full step location. If this input is left floating the drive will operate normally and respond to STEP and DIRECTION commands. This input can be changed at any time to freewheel the motor and is not latched to any other input or output.

STEP: A step pulse frequency is applied to this input to move the motor. The frequency and speed will depend on the microstep resolution chosen. The maximum frequency input is 2.5 MHz, allowing for a maximum speed of 2,929 RPM at the highest resolution of the R725.

DIRECTION: When a logic '0' is applied the R725 will move clockwise. When a logic '1' is applied the R725 will move counter clockwise. This input is a non-latching input and must be held at the desired logic level for as long as the motor must move that direction.

UNDERSTANDING OUTPUTS: FULLSTEP AND FAULT

The two optically isolated and CMOS buffered outputs on the R725, FULLSTEP and FAULT, are covered below. Both are compatible with 5VDC and 3.3VDC logic.

FULLSTEP: The R725 has an output dedicated to pulsing on every full step location (full current to one winding and zero current in the other) on the motor, acting somewhat like a tachometer. This means every revolution would be 200 pulses on the FULLSTEP on a standard 1.8 degree stepper motor.

FAULT: When the R725 encounters a FAULT state it will put the FAULT pin to a high state. The FAULT conditions that will trip the drive are:

- 1.) Cross phasing of the motor windings.**
- 2.) Phase to phase short circuit on the motor connections.**
- 3.) Over current on motor windings.**
- 4.) Reverse polarity on power supply input.**

If the R725 enters a FAULT state you can clear this by cycling the RESET input. This will put the drive back into a normal state, but if it faults again there may be a problem on the drive or the system.

The FAULT output can be set as a 4800 baud TTL-level UART.

Further FAULT information, including LED blink codes, can be found on Page 13 of this manual.

EXPLANATION OF FEATURES

Sub-Microstepping: At certain microstep resolutions the R725 will interpolate microsteps between rougher resolution choices. This means that the motor will move with the smoothness of a higher resolution option but will still have the lower input frequency requirement of the selected resolution. When operating in 2uStep, 4uStep and 8uStep modes the drive will interpolate to 16uStep motor smoothness. When operating at 5uStep the R725 will interpolate to 10uStep smoothness. Higher levels of interpolation have significantly diminished returns, which is why this affects only lower resolution choices.

Resonance Compensation: Using an entirely new method of motor control allows the R725 to eliminate nearly all resonance. The two-tier system the drive uses eliminates resonance at the 1st and 2nd harmonic and at the midband, increasing torque and motor stability in unstable step motor regions.

Full Step Morphing: Between 3 – 6 RPS the drive will morph from microstepping to a true full step output to the motor, increasing high speed motor torque by 40% over a microstepping only driver. This requires no input from the user and the drive will not need any modifications in the software controlling it to take advantage of this.

Soft Start: Step motors without a soft start drive operating them can draw significant inrush current. The R725 ramps up current to the motor to avoid startup noise and premature tripping of protection circuitry due to sudden current loads.

Spread Spectrum PWM: Most stepper controls have a fixed switching frequency which leads to motor harmonics and large EMI outputs. With spread spectrum PWM the R725 switches randomly between switching frequencies at every step, eliminating harmonic knocking and EMI interference.

Self-Test: A push button is used on the R725 to allow for quick in-the-field testing of the drive's core functionality. With a motor and power supply connected correctly the motor will turn at 1 RPS clockwise and counter-clockwise

as long as the button is held down. This button input will take priority over all other input signals, meaning if STEP and DIRECTION are connected and the button is held down the R725 will move in self-test mode.

Protection Circuitry: The R725 has rugged protection features to prevent damage in the majority of catastrophic events. It is protected against short-circuit, under-voltage, over-voltage, and over-temperature. The protection circuit will also detect an open motor phase and an unconnected motor. To clear a FAULT state the RESET input must be cycled to logic '0' for one second and then returned to a floating or logic '1' state.

LED Fault Codes: Two LEDs give a status indication with either a solid color or a blink-blink-blink-off status code. A tertiary LED will only light in the event the fuse blows and is labeled on the PCB as "FUSE" above the LED as seen in Figure 1. The Status LED codes can be found below:

COLOR CODE	STATUS MEANING
RED-RED-RED-OFF	Motor Disconnected
GREEN-GREEN-GREEN-OFF	Normal, motor not moving
RED-RED-GREEN-OFF	Phase A disconnected
RED-GREEN-RED-OFF	Phase B disconnected
GREEN-RED-RED-OFF	Unassigned
RED-GREEN-GREEN-OFF	Unassigned
GREEN-RED-GREEN-OFF	Unassigned
GREEN-GREEN-RED-OFF	Unassigned
SOLID RED	Drive is in protect mode
SOLID GREEN	Normal, motor moving

APPENDIX

This is a small section dedicated to using the R725 that did not fit in any specific section of the manual.

HEATSINKING CONSIDERATIONS

As with all stepper motor controls the R725 will create heat while operating. However, with the ultra-efficient power section the R725 will not heat nearly as much or as quickly as most other drives. Running at full power (80VDC, 7A, 120RPM) the delta-T is approximately 68C after 30 minutes; ambient temperature will determine the amount of heatsinking necessary. We recommend keeping the maximum temperature in the commercial range, or 70C, though the majority of components are industrially rated at 85C.

The most important aspect to heatsinking is proper airflow. A small fan can provide significant circulation in most systems and should blow over the fins of any heatsink that is used. Adjusting the standby current trimpot can significantly impact your drive and motor heating at idle, so for non-load-bearing applications (i.e. a vertical axis) it is recommended to adjust it to 70% or less.

ENVIRONMENTAL RATINGS

The R725 is rated for commercial use, with an operating temperature range of 0C – 75C (32F – 167F) and a humidity range of 0 – 95% non-condensing. Use in environments outside of those ranges are not advised but Lin Engineering support can recommend workarounds in some cases.

REPLACING THE FUSE

Replacing the fuse on the R725 can be done quickly in the field. The fuse plugs into two sockets and can be removed with tweezers, pliers, or by hand. The part number for the fuse is 0251007.MXL and it will need its leads formed at the same distance as the sockets, cut to length and pushed in. Make sure that the fuse resists being pulled out at both ends to ensure a proper fit.

DISCLAIMER

CERTAIN APPLICATIONS USING POWER PRODUCTS MAY INVOLVE POTENTIAL RISKS OF DEATH, PERSONAL INJURY OR SEVERE DAMAGE TO PROPERTY. LIN ENGINEERING INC. PRODUCTS ARE NOT DESIGNED, AUTHORIZED OR WARRANTED TO BE SUITABLE FOR USE IN LIFE-SUPPORT DEVICES OR OTHER CRITICAL APPLICATIONS. INCLUSION OF LIN ENGINEERING INC. PRODUCTS IN SUCH APPLICATIONS IS UNDERSTOOD TO BE FULLY AT THE PURCHASER'S OWN RISK

In order to minimize risks associated with the purchaser's application, adequate design and operating safeguards must be provided by the purchaser to minimize inherent or procedural hazards. LIN ENGINEERING INC. assumes no liability for applications assistance or the purchaser's product design. LIN ENGINEERING INC. does not warrant or represent that any license, either express or implied, is granted under any patent right, copyright or other intellectual property right of LIN ENGINEERING INC.